

Box(Suzhou) Technology Co., Ltd.
400 800 2025

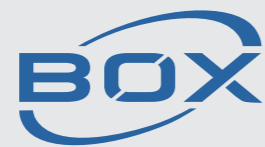

Application of New Machine Vision and Artificial Intelligence Technologies in Thermos Manufacturing



Intelligent vision

Continue to help customers upgrade and develop

Box(Suzhou) Technology Co., Ltd.

- Contact | Mr. Mao
- Tel. | 134 2627 9907
- E-mail | maoliang@softrobottech.com
- Suzhou headquarters | Floor 21, Gaorong Building, High-speed Railway New Town, Xiangcheng District
Suzhou factory | No. 888, Fengyang Road, Xiangcheng District
Yongkang base | No. 28, West Jinshan Road, Yongkang City



WeChat

Innovation, Excellence, Struggle and Virtue

Core technology of machine vision | Investigation and research of machine vision application
Evaluation of machine vision application | New technology application | Machine vision product

BOX products are protected by patent and copyright laws. In order to ensure the accuracy of the information in this material, it is forbidden to copy or modify its contents. The right of final interpretation of this information belongs to BOX.zz

01	Company Profile Machine vision product and solution provider	03
02	Core technology of machine vision Optical patent design, Domain algorithm IP	04
03	Investigation and research of machine vision application Process flow analysis, Vision applications in existing processes ,Vision applications upon automation	06
04	Evaluation of machine vision application Vision application analysis	08
05	New technology application Visual positioning, Appearance inspection, Smart line type	10
06	Machine vision product Thermal shadow thermometer、 Dimensional measurement instrument、 Graphics and texts inspection machine、 Angle positioner etc.	11

“Box” subsidiary of SRT Vision

Box(Suzhou) Technology Co., Ltd., a subsidiary of SRT established in 2019, is a leading solution and equipment manufacturer and service provider in China, which integrates machine vision and industrial intelligence both in one. The company has a deep background in visual technology research and development, a leading visual algorithm R&D team, and a professional technical team, and owns a number of core technologies and independent intellectual property rights in the fields of visual positioning, visual measurement, visual inspection and visual recognition.



| 2019 Huanxiu Lake Leading Talent Enterprise | 2020 Xiangcheng District Leading Talent Enterprise | 2021 Gusu District Leading Talent Enterprise

Honors and qualifications



Industry application

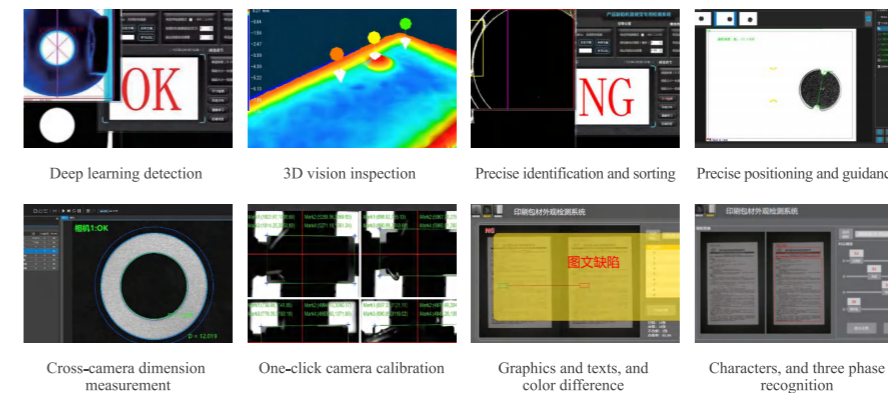

Machine vision product and solution provider

Core technology of machine vision

Optical patent design

BOX TECH Domain algorithm IP

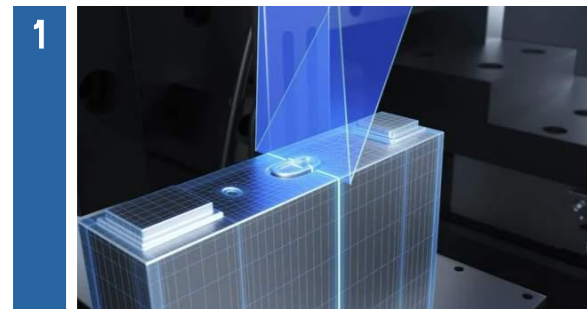

360° imaging system for highly reflective curved products

Features | It can completely remove dark shadows on high-gloss surfaces

Advantages | Strong resistance against optical interference

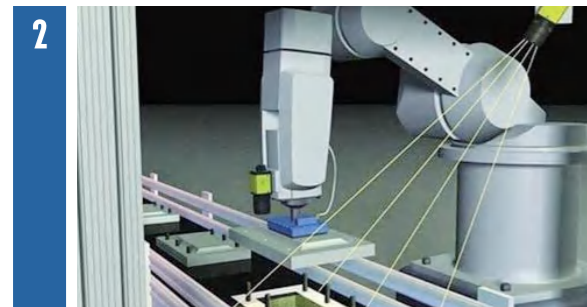

Strong resistance against optical interference

Features | Full coverage of planes, curved surfaces and R angle

Advantages | Strong adaptability to surface morphology

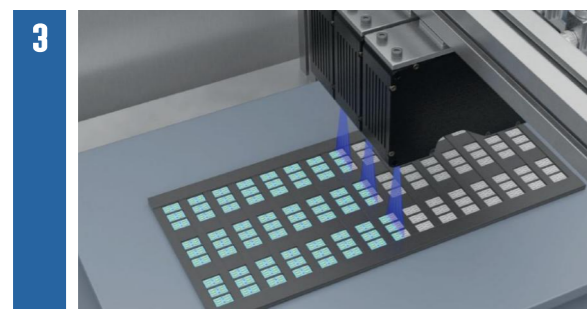

X-ray, short-wave infrared, and 3D vision explosion-proof imaging system

Features | It can extract richer product features

Advantages | Strong multispectral significance

Metal appearance defect detection algorithm

Features | Combination of deep learning and artificial models

Advantages | Higher defect detection rate and more accurate attribution

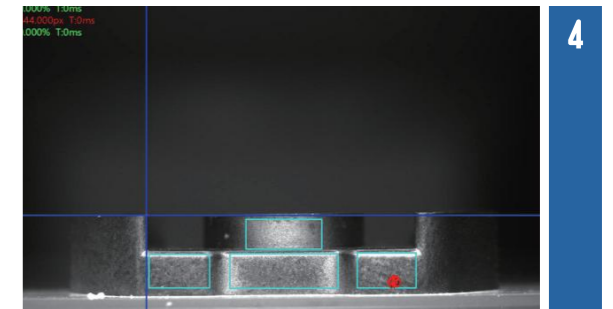

Multi-camera dynamic calibration and measurement algorithm

Features | Large-size products can be measured across cameras

Advantages | Micron-level precision, high efficiency, and low cost

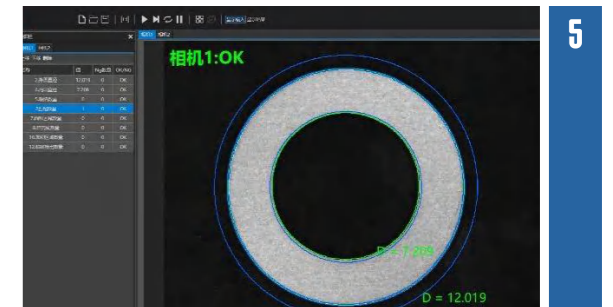

Multispectral detection algorithm

Features | Multi-camera multi-modal analysis

Advantages | Up to 99.7% of algorithm accuracy

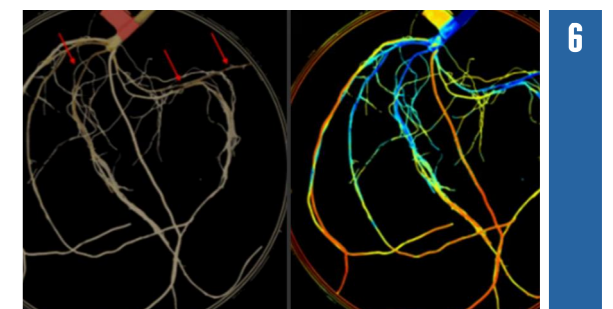

Investigation and research of machine vision application

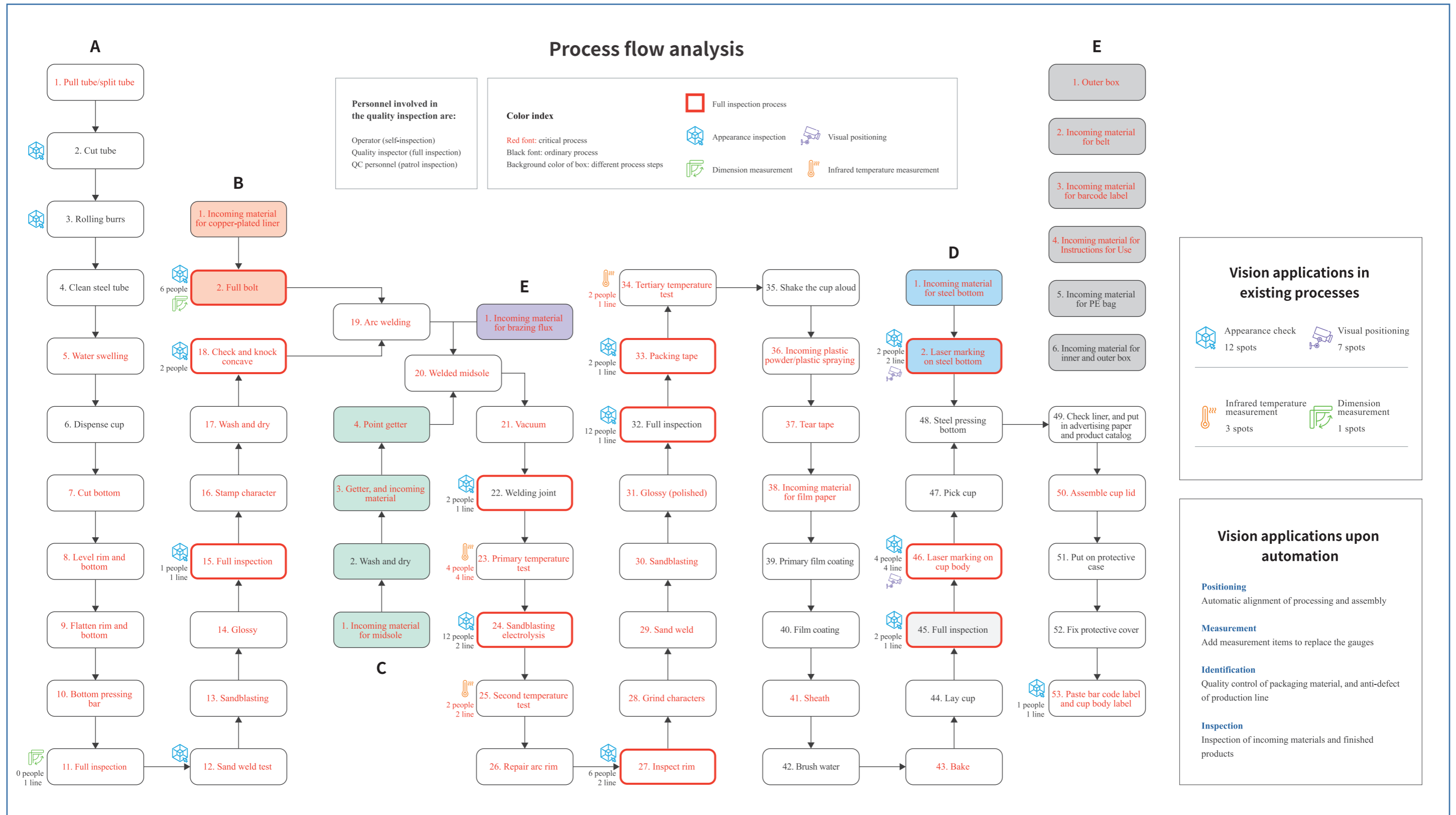

Evaluation of machine vision application

Vision application analysis

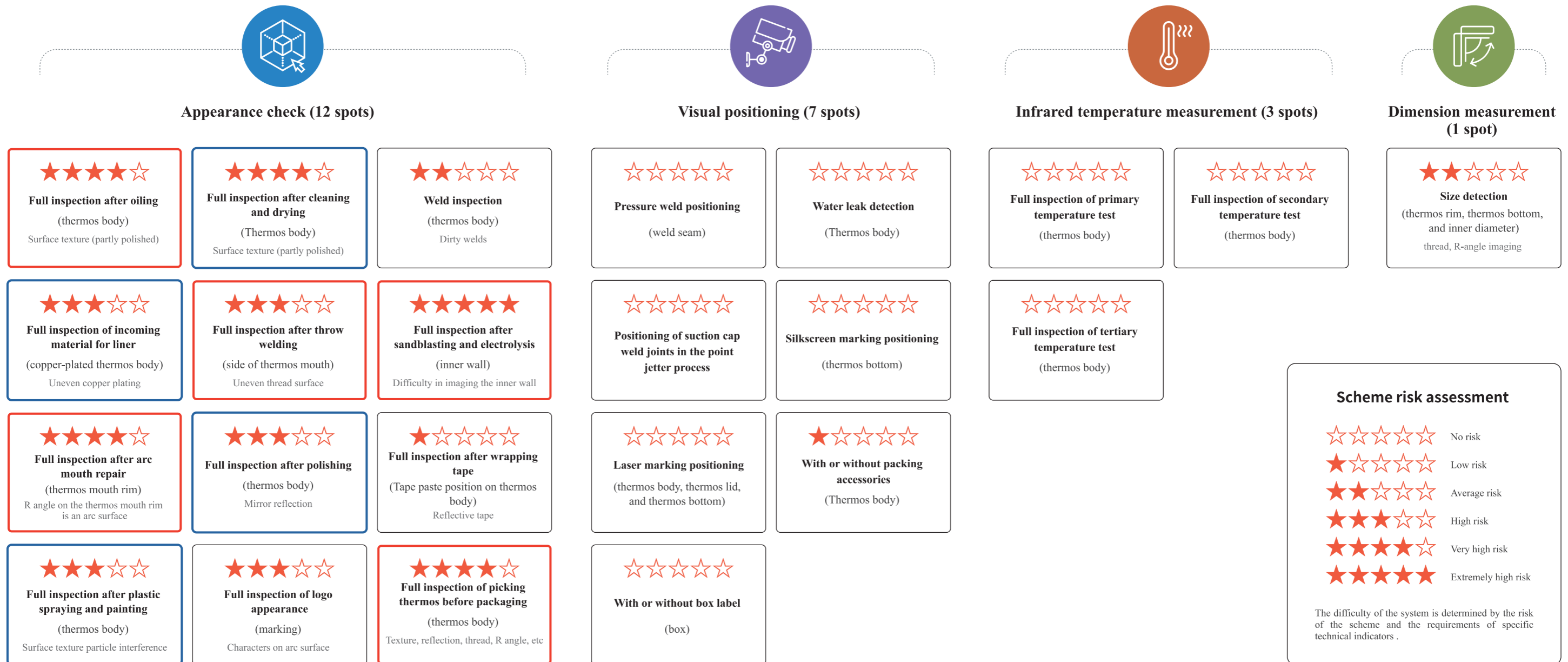

It is recommended that the first stage be selectively developed and the effects verified.

It is suggested that in the second stage, select key areas to seek breakthrough and optimize the scheme based on existing achievements.

It can be upgraded at any time according to the needs of production line transformation.

New technology application

Visual positioning

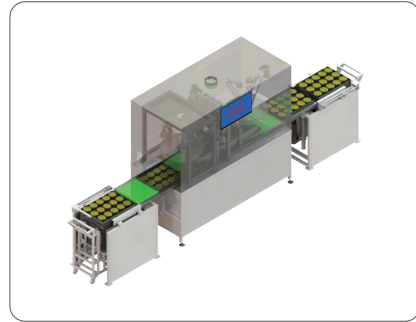

Thermos lid laser flying marking equipment

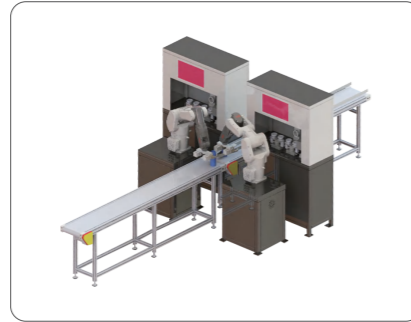

Automatic thermos bottom/body marking equipment



Visual galvanometer welding

Appearance inspection



Printing packaging material defect detection equipment

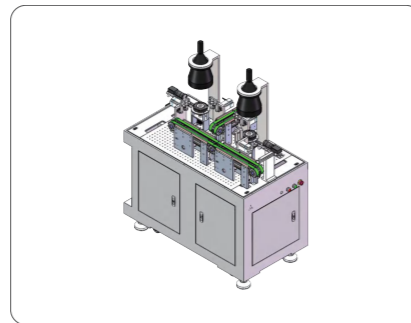

Welding film defect detection equipment

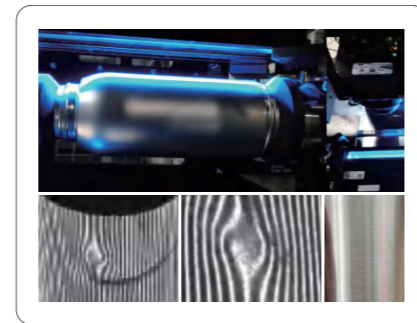

Polishing thermos appearance inspection equipment

Smart line type

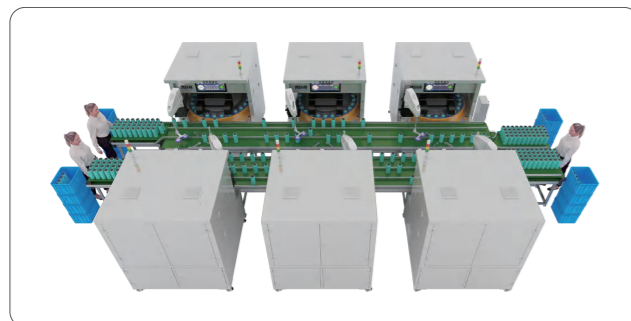

Centralized automatic temperature measurement line - temperature measurement robot workstation



Automatic line for marking, capping, and packaging

Machine vision product

The latest breakthrough of Manufacturing technology for vacuum cups by applying artificial intelligence (AI) and machine vision technology

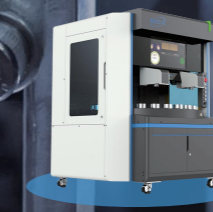

Thermal shadow thermometer



Dimensional measurement instrument



Graphics and texts inspection machine

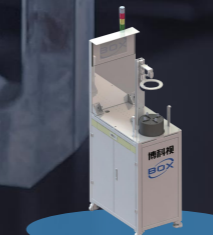

Angle positioner

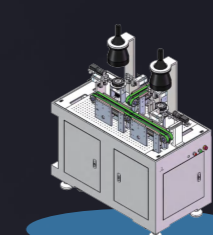

Welding film appearance inspection equipment

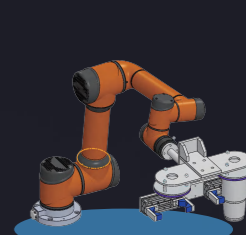

Intelligent end executor for leak detection

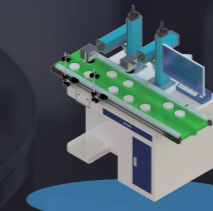

Visual galvanometer welding

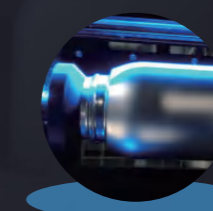

Thermos appearance inspection

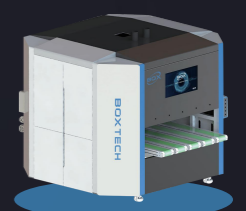

Visual laser marking workstation

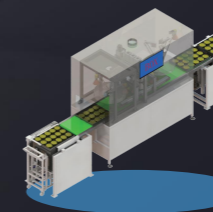

Bottom cover vision flying marking line

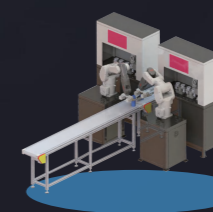

Thermos body marking workstation

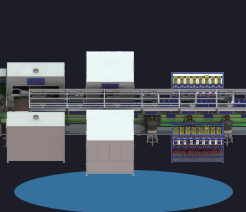

Semi-automatic digital packaging line

Thermal shadow thermometer



Software interface



- ▶ Quality and energy consumption analysis
- ▶ Continuous production with mixed materials
- ▶ Cup recipe management
- ▶ Intelligent voice broadcast
- ▶ Self-learning via online template
- ▶ One-click changeover
- ▶ Foreign object safety monitoring
- ▶ Production report management
- ▶ Remote upgrade and maintenance
- ▶ Automation protocol interface

Product parameters

Product name	Thermal Shadow Thermometer	Visual sensor	2 high-precision industrial-grade thermal imaging cameras
Number of workstations	25	Auxiliary configuration	27-inch large screen, voice broadcast, and electronic control regulation
Average hourly production capacity	800 pieces/hour~850 pieces/hour	Service life of heating body	>2 years
Average hourly power consumption	0.8KWH~2KWH	System software	Smart Vision TMS 3.0 ,Lifetime free upgrade
Compatible cup diameter	<120mm	Cup body weight	700KG
Compatible cup height	>90mm, <320mm	Product size	1540mm×1600mm×1950mm (length × width × height)
Judgment accuracy	>99.5%	Working environment	temperature: -10 C ~50 C humidity: 30%-80%
Single cup heating time	>100seconds	Power supply	220V, 50Hz

Temperature measuring robot workstation

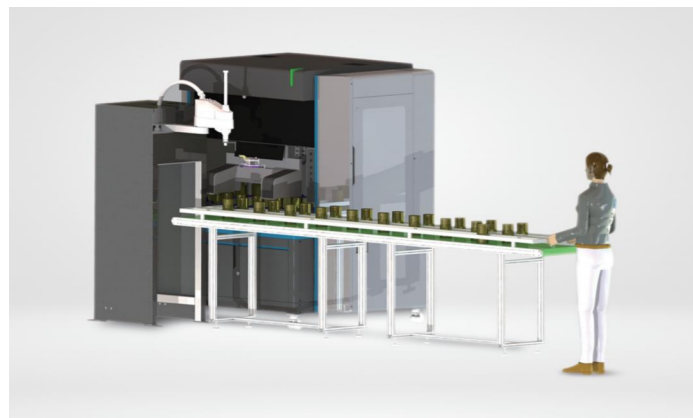

The workstation can be quickly embedded into the production line to realize automatic temperature measurement and reduce the manpower needed. After expanding or cascading the buffer area, one person can manage multiple thermometers.

- 1 Thermal shadow thermometer for thermos cup**
The thermal shadow thermometer can be used to replace the traditional temperature measurement and detection process of the thermos cup, thus helping customers realize the intelligent management of the temperature measurement process.
- 2 Loading/unloading four-axis robot**
Using four-axis robots to assemble double-headed flexible suction cups not only applies to various cup models, but also improves the tempo of the production line and replaces manpower.
- 3 Loading/unloading/conveyor belt**
The return conveyor belt is used, which is divided into the loading belt, NG belt, and PASS belt, to avoid material mixture.

Automatic line for temperature measurement

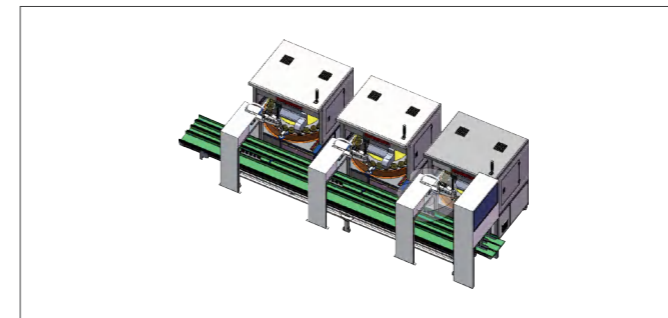
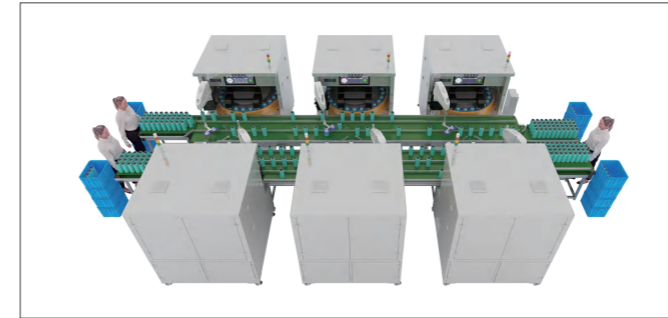

Two-line centralized temperature measurement production line

- Production capacity of a single shift: 50,000
- 3 people required for loading and unloading
- Production capacity of a single shift: 50,000 pieces/shift

Centralized temperature measurement production line

- Centralized loading and unloading, higher personnel efficiency
- Primary and secondary temperature measurements can be repeated to improve utilization
- Each device can produce independently to improve flexibility
- One-click changeover and digital kanban of central control platform, to improve management efficiency
- Production capacity of a single shift: 25,000 pieces/shift

Standard version



Temperature measuring robot workstation

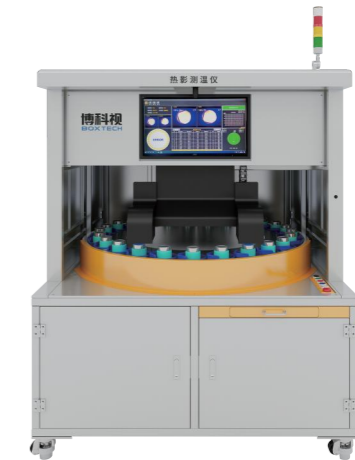

Thermal shadow thermometer

Dimensional measurement instrument



Product description

- It is suitable for the high-precision measurement of external dimensions of the cup mouth, cup body and cup bottom in the thermos production line;
- The system is equipped with high-precision optical devices to realize the precise measurement of profile of metal surfaces;
- Based on the independent Smart Vision technology, it provides users with friendly human-computer interaction software;
- It enables the automatic loading and unloading with the mechanical arm, 360° automatic measurement of the cup body by one click, and switching and calibration of product changeover template by one click.

Product features

- ★ High-precision non-contact measurement (accuracy of 0.01mm);
- ★ 360° rotation automatic detection (<5 seconds/piece);
- ★ Large field of view imaging to enable full-scale detection of points, lines, circles, arcs and angles of measurement objects such as cup mouth, cup body and cup shoulder;
- ★ Cross-camera measurement can not only realize the full inspection with large field of view, but also optimize the equipment hardware;
- ★ Loading and unloading by manipulator to realize automatic detection;
- ★ Friendly, easy-to-operate human-computer interface;
- ★ One-click changeover;
- ★ Templates can be customized according to the measurement scenes.

Dimensional measurement workstation

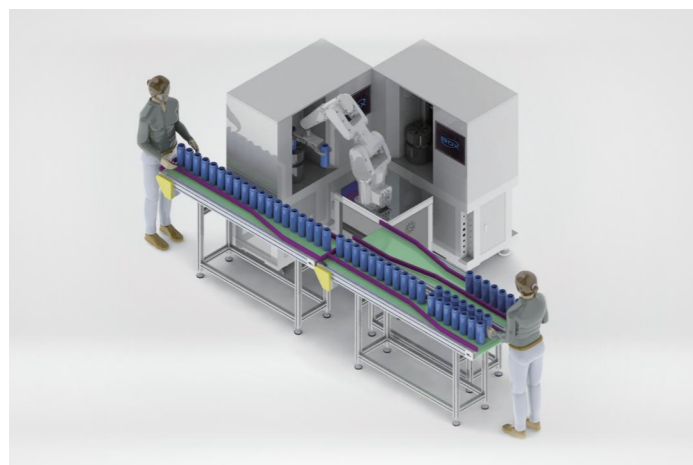

The workstation is designed for automatic loading and unloading with a six-axis robot. Materials can be placed on the conveyor line manually, or the conveyor line is directly linked to the upper and lower processes without involvement of manpower. The equipment in the scheme is outfitted with 1 set of robot, 2 sets of dimension measuring instruments, and 1 set of manipulator as standard: 1 set of loading line, 1 set of unloading line, and 1 set of substandard product bakflow line are optional.

1 Thermos cup size measuring instrument

The machine is equipped with a high-precision optical device, which can measure the external dimensions of the cup mouth, cup body, and cup bottom with high precision, and the profile of metal arc surfaces with precision.

2 Loading/unloading six-axis robot

The double-claw six-axis robot can meet the requirements of large-angle rotation and long-distance loading and unloading. The double-claw design facilitates loading and unloading to improve the tempo of the production line.

3 Loading/unloading/NG product conveyor belt

Three combined conveyor belts, for PASS/NG products, are used to prevent mixed feeding.

Graphics and texts inspection machine



Fields of application

Random inspection of incoming printing and packaging materials.

Functions of the equipment

Detect such defects as missing materials, wrong materials, deformation, missing printing, extra printing, mistakes, stains, and characters and graphics of wrong sizes; read the QR codes and barcodes; support simultaneous detection of multiple products; automatically match templates.

Advantages

Improve the quality control of the inspection for incoming printing and packaging materials.



BOXTECH

Angle positioner



Welding film appearance inspection equipment

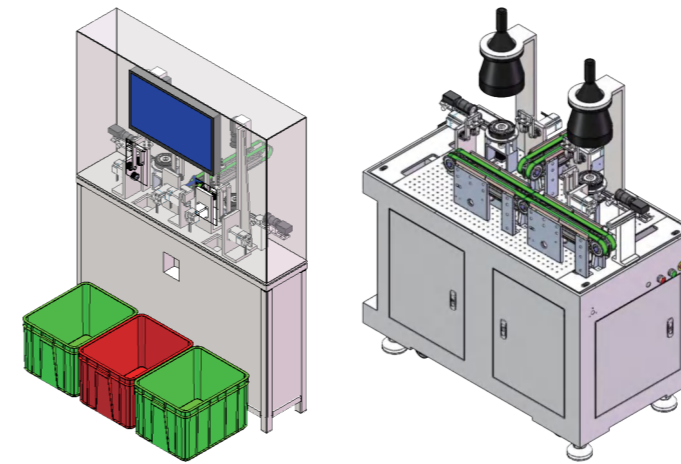

Fields of application	For the flat bottom, arc bottom and sleeve bottom of the thermos, conduct the appearance defect detection of incoming materials to improve the yield rate of subsequent welding.
Functions of the equipment	Detect such appearance defects as gaps, burrs, dents, and warping of the film, measure the diameter of the film, and alarm and remove defective products.
Advantages	It can be connected to the contact point getter equipment, with fast detection speed, and control the quality of the incoming material before welding to improve the welding yield.

Fields of application	Identify the welding seam, LOGO, sink mark and other parts of the thermos, and automatically rotate to the specified angle after the identification.
Functions of the equipment	One-click automatic operation, jog control, stop and other functions, real-time display of detection images, detection of data and results, operation status, NG alarm and fault prompts, internal and external weld seam detection, creation of new templates, adjustment and editing of template parameters, and generation and storage of multiple templates.
Advantages	According to specific products, angles can be positioned from the top or side, and product changeover can be completed with one click. Based on the independent Smart Vision technology, it provides users with precise positioning and a friendly interface.

Intelligent end executor for leak detection

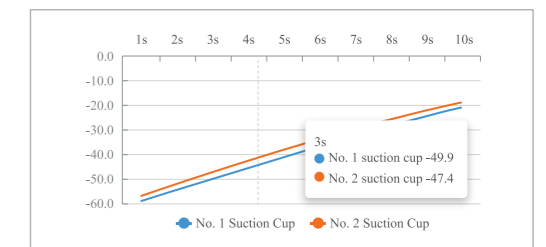
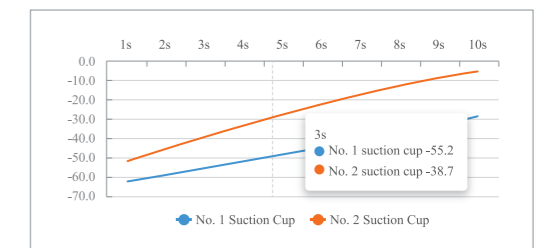
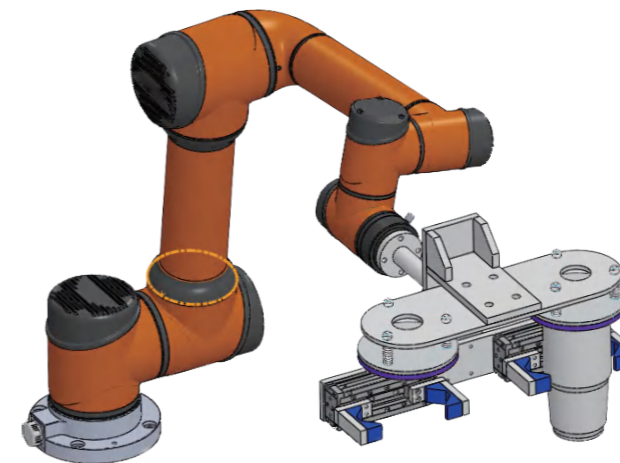

Angle positioning workstation

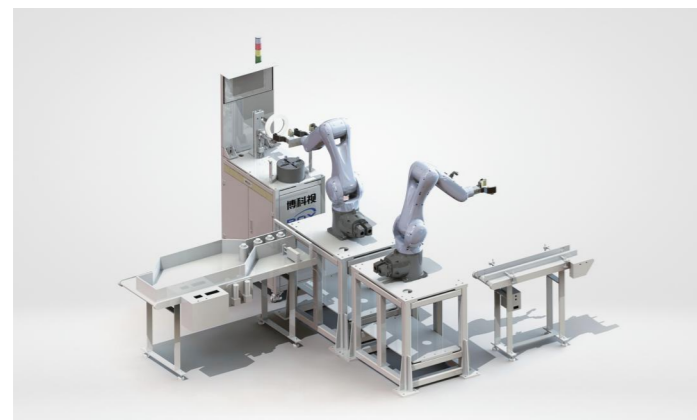

The workstation mainly provides the integrated customization and robot debugging services at the automated workstation for the angle positioning of the thermos cups, to realize the fully automatic loading/unloading and visual positioning inspection of the workstation.

- 1 Thermos cup image locator**
The device can detect the cup model at different weld seam positions as demanded, with the internal weld seam compatible with the external weld seam.
- 2 Loading/unloading six-axis robot**
The double-claw six-axis robot can meet the requirements of large-angle rotation and long-distance loading and unloading. The double-claw design facilitates loading and unloading to improve the tempo of the production line.
- 3 Guide/feed conveyor belt**
The backflow method can avoid material jam and uninterrupted cycled transmission.

Fields of application	Leak test for the thermos liner.
Functions of the equipment	Leak test shall be done during the transportation.
Advantages	It can be integrated into the end of the robot together with the gripper, reducing one set of equipment and robot, and realizing the digitalized leak testing.

Visual galvanometer welding

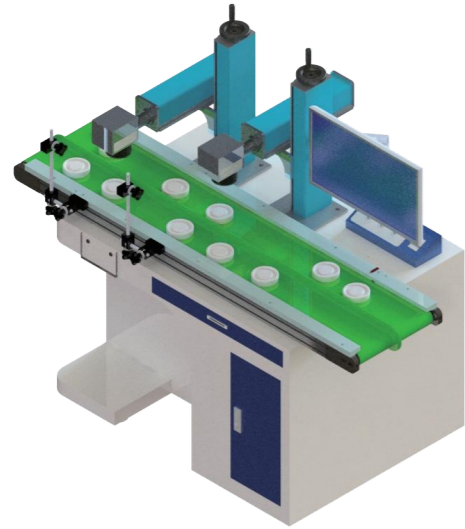

Fields of application	Straight welding of thermos.
Functions of the equipment	Visually locate the welding area, dynamically generate the welding trajectory, and guide the laser for automatic welding with the galvanometer.
Advantages	No jigs and robots are needed for the handling, but the production capacity is doubled, causing lower cost; it can effectively solve the problem of welding quality control of unrounded thermos.

Visual laser marking workstation

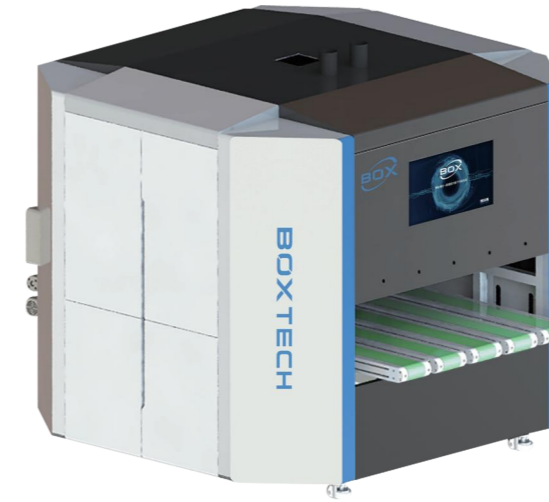

Fields of application	It is used for marking on thermos to realize marking on the bottom of plastic-sprayed thermos.
Functions of the equipment	Automatically fix the angle of the thermos bottom and handle, and realize functions such as guided marking, air-cooled cooling of thermos body, digital kanban and recipe management. It can be connected with the corporate information system.
Advantages	Improve the production capacity and replace the original manual marking. Automatically guide the marking via vision to improve the marking quality.

Thermos appearance inspection

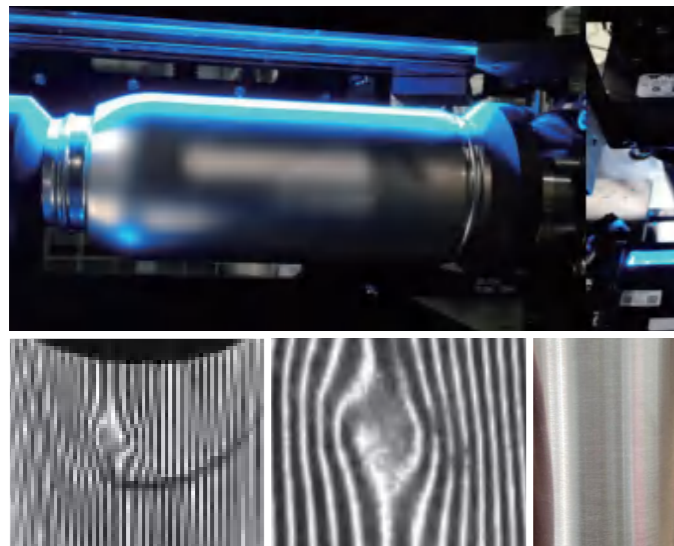

Fields of application	Inspection of appearance defects in the polishing section of the thermos.
Functions of the equipment	Detect large wire drawing and pit defects.
Advantages	Reduce the labor intensity of human quality control, increase quality control methods, and improve the pass-through rate.

Bottom cover vision flying marking line

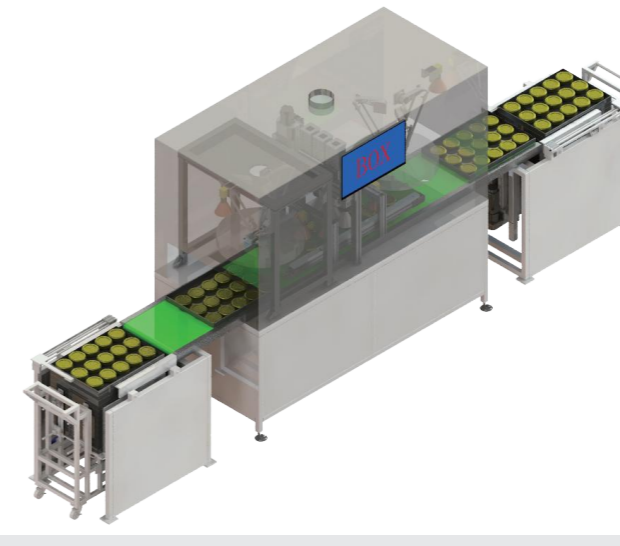

Fields of application	Marking on the steel bottom of the thermos.
Functions of the equipment	Control the multi-channel flying marking, guide the robot loading and unloading, check the marking quality, change type automatically etc.
Advantages	Collectively load the equipment, reduce personnel and improve efficiency, reduce land occupancy, and shorten the time for machine commissioning and model change.

Thermos body marking workstation

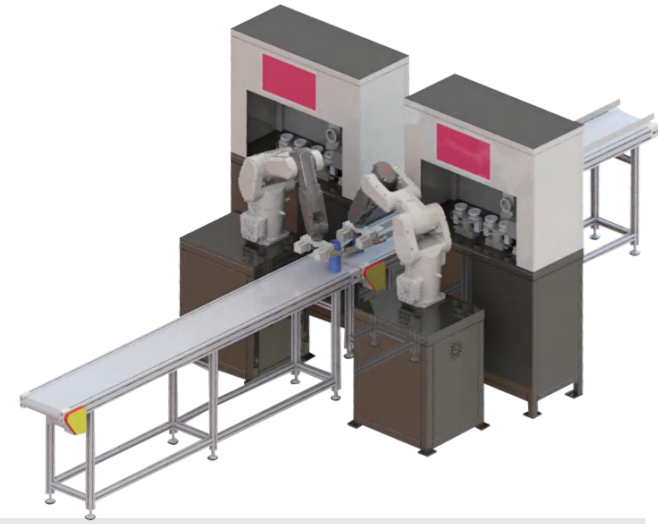

Fields of application	Mark the thermos body.
Functions of the equipment	Control the rotation of the turntable, automatically locate the thermos body by vision, automatically mark and change the shape after rotation to the prescribed position.
Advantages	High marking accuracy to improve the marking yield; automatic type changeover to reduce machine changeover time; double-cubicle marking to improve marking efficiency.

Semi-automatic digital packaging line

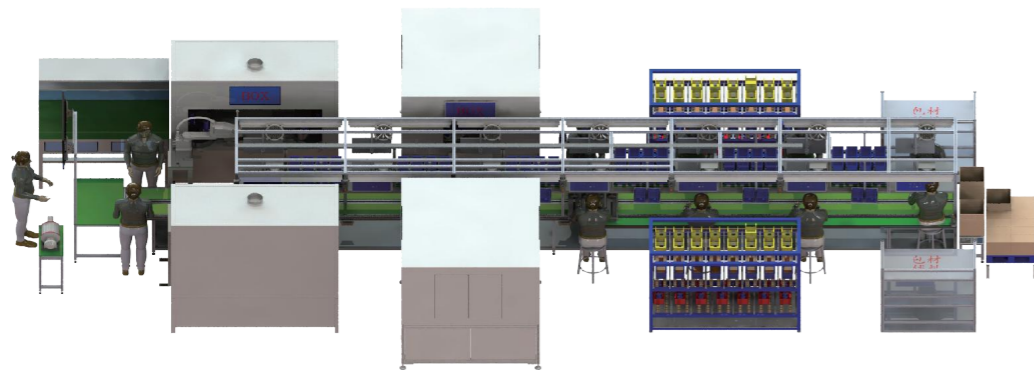

BOXTECH

Fields of application	Functions of the equipment	Advantages
Thermos packaging line.	Automatic marking on the thermos body, automatic glue dispensing and capping, and digital kanban, which can be connected to the digital system.	Automatic marking and capping can reduce operators and improve the product yield; conduct digital and informationized display to improve the corporate management level.